

GREATER NEW HAVEN WATER POLLUTION CONTROL AUTHORITY CONSTRUCTION DETAILS

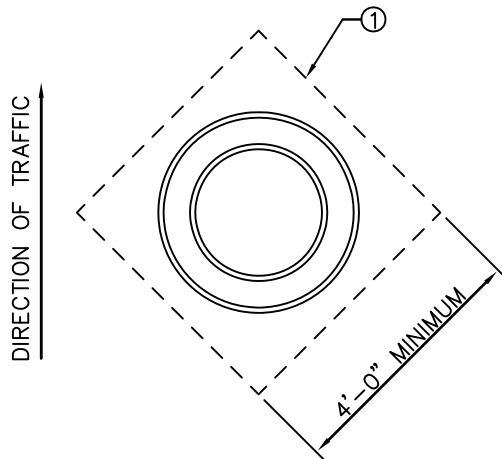

PLAN

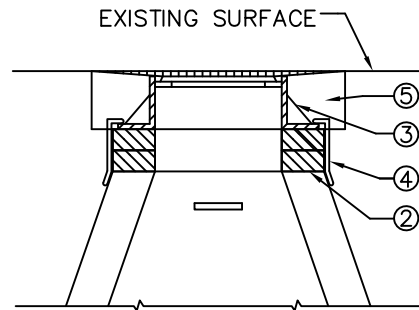

SECTION

NOTES:

1. CUT AND REMOVE EXISTING PAVEMENT TO NEAT LINES AS SHOWN OR AS DIRECTED. REMOVE BITUMINOUS CONCRETE FROM MANHOLE FRAME AND COVERS. CIRCULAR PAVEMENT CUT AROUND MANHOLE COVER ALSO ACCEPTABLE.
2. REMOVE AND REPLACE EXISTING MORTAR AND MASONRY WHICH IS LOOSE, DETERIORATED OR UNSOUND AS DIRECTED BY THE ENGINEER.
3. SET MANHOLE FRAME TO REQUIRED GRADE WITH MANHOLE GRADE RINGS OR AS DIRECTED BY THE GNHWPCA. MANHOLE FRAMES ARE TO BE SET IN FULL MORTAR BEDS.
4. INSTALL EXTERNAL BANDED FLEXIBLE ELASTOMERIC SEAL, CRETEX OR APPROVED EQUAL.
5. REPLACE PAVEMENT WITH 3" BITUMINOUS CONCRETE CLASS 1 LAID IN TWO COURSES ON 4" BITUMINOUS CONCRETE CLASS 4 LAID ON TAMPED SUBBASE. SEAL PAVEMENT JOINT WITH ASPHALT.
6. CONTRACTOR TO FURNISH NEW MANHOLE FRAME AND COVER AS REQUIRED.
7. EXISTING MANHOLE FRAME AND COVER TO BE DISPOSED OF AS DIRECTED BY THE ENGINEER.

REVISIONS	
NO.	DATE
1	JUNE 2008
2	MARCH 4, 2009

TYPICAL MANHOLE COVER RAISING NTS