

# GREATER NEW HAVEN WATER POLLUTION CONTROL AUTHORITY CONSTRUCTION DETAILS

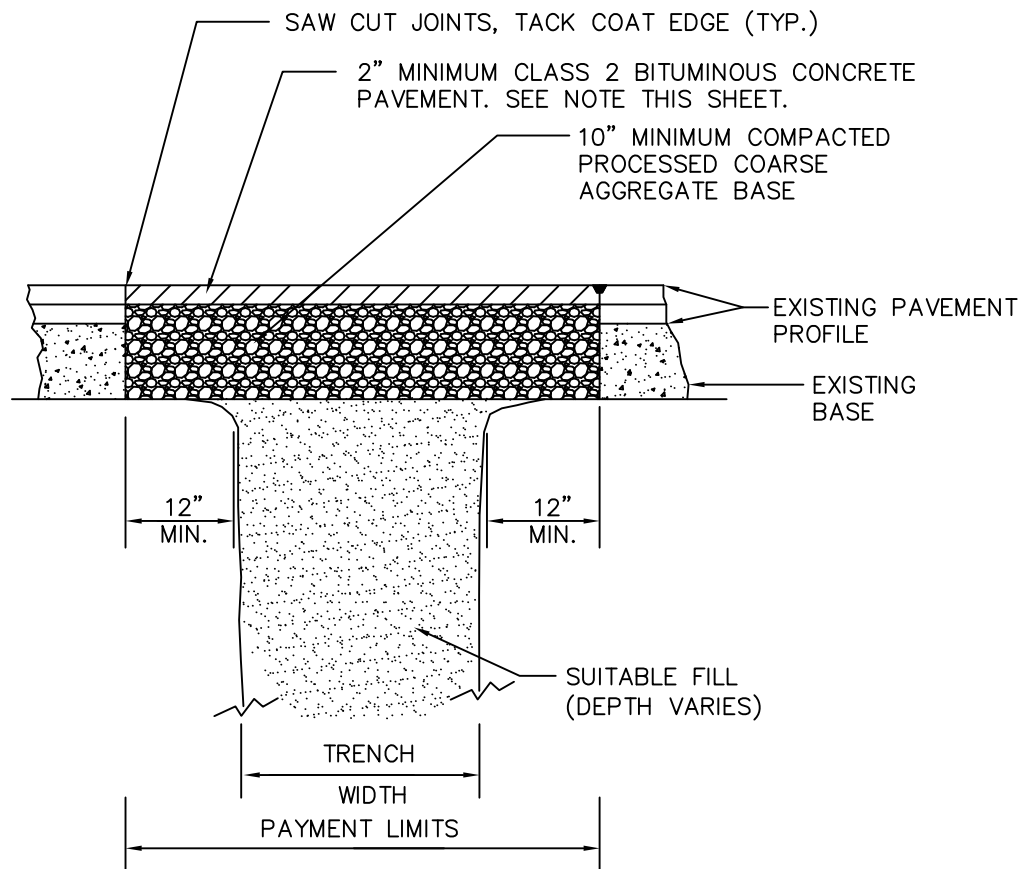

**NOTES:**

- AFTER NOVEMBER 15TH, ASPHALT MIX SHALL BE APPROVED BY THE ENGINEER.
- CLASS 2 MIX DESIGNATION IS NOW HMA S0.375



## TEMPORARY PAVEMENT REPAIR ON LOCAL ROADS

NTS

REVISIONS	
NO.	DATE
2	JANUARY, 2020